

SE TYPES

Dutchclamp® SE cable clamps are specially designed for short-circuit resistant fastening of single or multicore medium and high voltage cables. SE types are available in 7 models and suitable for cables with a diameter from 15 mm to 170 mm.

Dutchclamp® SE cable clamps are unique in their kind. The surfaces wherein the cables come to lie ensure perfect pressure distribution and maximum grip on the cables without sharp edges. In this way, there is no point load on the cables and the cables are not damaged. Dutchclamp SE cable clamps are manufactured from the highest quality, glass fibre reinforced polyamide and are therefore ideally suited for installations where very high short circuit forces may occur.

The unique raw material used in manufacturing these cable clamps, makes them resistant to corrosion, ozone, frost, heat, oil, acids, salts, aggressive chemicals, UV and nuclear radiation. There is no reduction in force within temperatures from - 40° C to + 125° C. (225° C momentarily).

Dutchclamp® SE cable clamps have been tested by, among others, UL (The Underwriters Laboratories U.S.A), the Prof. Ir. Damstra laboratory (Eaton) Voltalab Grenoble (Schneider) and SGS Brussels in accordance with the DIN EN IEC 61914:2023 international standard. All test reports are available upon request.

Dutchclamp® SE cable clamps are used worldwide and are therefore available from stock. They can also be supplied with appropriate fastening material.

Certified in accordance with the DIN EN IEC 61914:2023 international safety standard

Dutchclamp has been developing and producing innovative cable clamps and cable blocks for installation of low, medium and high voltage cables since 1982. The clamps have been designed in close collaboration with major energy companies. Dutchclamp is globally renowned for its quality, service and reliability. The Dutchclamp cable clamps and cable blocks are now being successfully used in more than 50 countries around the world.

The design

By way of the specific unique model, each type of cable clamp provides an exact fit for the required short-circuit resistant installation.

The raw material

Dutchclamp cable clamps are produced from high-quality virgin raw materials, with glass fibre reinforced polyamide as the main ingredient. The Dutchclamp cable clamps are self extinguishing and halogen free.

Robustness

Owing to the unique design combined with the specific composition of the raw materials, these plastic cable clamps are among the strongest in the world. They are specially designed to withstand the enormous forces that occur during short circuiting and have been tested by various laboratories.

Tests

The cable clamps have been tested by, among others, UL (The Underwriters Laboratories U.S.A), Prof. Ir. Damstra Laboratory (Eaton), Volta laboratory in Grenoble (Schneider), KEMA and SGS Brussels, in accordance with the DIN EN IEC 61914:2023 international standard.

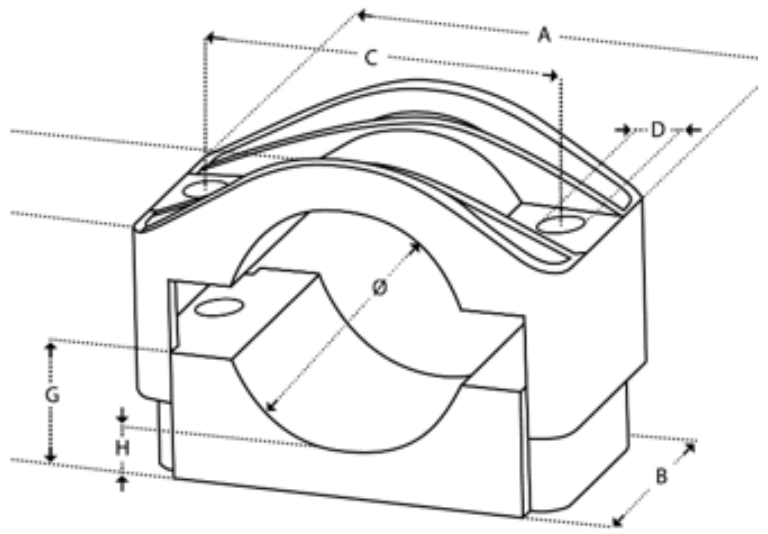

Dimensions in mm										N*
Typ	Cable-Ø	A	B	C	D	E	F	G	H	
SE 15-26	15-26	77	45	50	10	26-42	4	17	8	8000
SE 26-38	26-38	92	60	60	12	33-49	7	18	7	12000
SE 36-52	36-52	105	60	75	12	39-55	15	23	8	12000
SE 50-75	50-75	126	60	95	12	46-71	22	30	9	12000
SE 75-100	75-100	200	80	150	15	70-95	32	45	10	20000
SE 100-135	100-135	225	85	175	15	85-120	43	58	10	20000
SE 135-170	135-170	260	90	210	15	133-169	62	90	28	20000

*Mechanical resistance to short-circuits in Newton

Advantages

- Resistant to short-circuit currents up to 202 kA
- Resistant to oils, fats, aggressive chemicals, frost, heat, UV, ozone, salt, moisture, acids, and nuclear radiation
- Self-extinguishing UL94, Halogen free.
- Temperature range from -40 °C to 125°C. (225°C momentarily).
- Coloured black
- No magnetism / conductivity
- Custom mounting available
- Fastening materials can be supplied to size
- No oxidation / corrosion
- No sharp angles
- Recyclable
- Lifetime warranty
- Very simple installation
- Available worldwide
- Certified in accordance with DIN EN IEC 61914:2023

